

機械加工寸法差 MACHINING TOLERANCE	
呼び寸法区分	寸法差 中級
1以上 4以下	±0.1
4をこえ16 "	±0.2
16 " 63 "	±0.3
63 " 250 "	±0.5
250 "1000 "	±0.8

25 / ( √ 6.3 / 1.6 / )

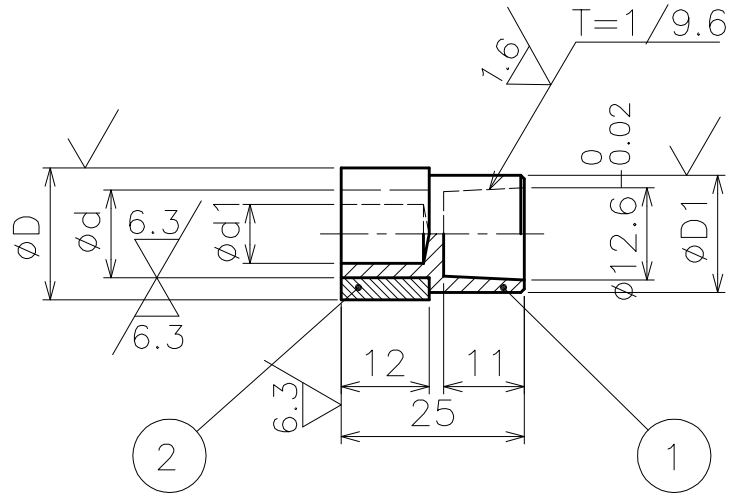

Nut Size	Model No.	Drawing No.	φD	φD1	φd	φd1
M4	W-PN-S4	SY-0248-01	16	16	9	4
M5	W-PN-S5	SY-0248-02	16	16	10	5
M6	W-PN-S6A	SY-0248-03	16	16	10	6
M6	W-PN-S6B	SY-0248-04	16	16	11	6
M6	W-PN-S6C	SY-0248-05	16	16	12	6
M8	W-PN-S8A	SY-0248-06	18	16	12	8
M8	W-PN-S8B	SY-0248-07	18	16	13	8
M8	W-PN-S8C	SY-0248-08	18	16	15	8
M10	W-PN-S10	SY-0248-09	22	20	17	10
M12	W-PN-S12	SY-0248-10	25	25	22	12

記 1、各稜系面取りの事

2		1	SS400	φD×14		
1		1	CrCu	φD1×28		
項 ITEM	品名 PART NAME		個数 Q'TY	材質 MAT'L	寸法 / 部品番号 SIZE/PARTS No.	記事 REMARKS
承認 APPROVED	承認 APPROVED	設計 DESIGNED	製図 DRAWN	尺度 SCALE	W-PN-S <input type="text"/>	
				個数 Q'TY	Nut Checker	
				日付 DATE	2014.7.29	
SAITAMA YOZAI CO.,LTD.				図番 DRAW'G No. / 部品番号 PARTS No. SY-0248- <input type="text"/>		