

機械加工寸法差 MACHINING TOLERANCE	
呼び寸法区分	寸法差 中級
1以上 4以下	±0.1
4をこえ16 "	±0.2
16 " 63 "	±0.3
63 " 250 "	±0.5
250 "1000 "	±0.8

25/ (✓ 6.3/)

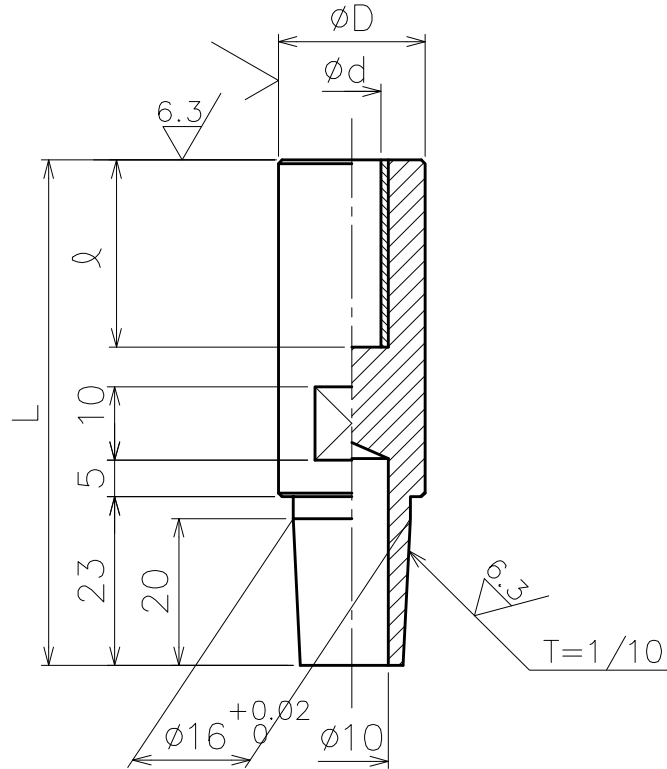

Bolt Size	Model No.	Drawing No.	φD	φd	ℓ	L
M4	W-PB-K4	SY-0301-01	16	4.2	22	60
M5	W-PB-K5	SY-0301-02	16	5.2	30	70
M6	W-PB-K6	SY-0301-03	18	6.2	30	70
M8	W-PB-K8	SY-0301-04	18	8.2	30	70
M10	W-PB-K10	SY-0301-05	22	10.2	30	80
M12	W-PB-K12	SY-0301-06	30	12.2	30	80

*但し、穴の深さは40ℓ
*Depth=40ℓ
*但し、穴の深さは40ℓ
*Depth=40ℓ

記 1、各稜系面取りの事

2	Sleeve	1	KCF	φ(d+2) × <input type="text" value="ℓ"/>		
1		1	CrCu	φD × <input type="text" value="L+4"/>		
項 ITEM	品名 PART NAME		個数 Q'TY	材質 MAT'L	寸法 / 部品番号 SIZE/PARTS No.	記事 REMARKS
承認 APPROVED	承認 APPROVED	設計 DESIGNED	製図 DRAWN	尺度 SCALE	W-PB-K <input type="text" value=""/>	
				個数 Q'TY		
				日付 DATE	2014.7.20	
SAITAMA YOZAI CO.,LTD.					Lower Electrode for Welding Bolt	
					図番 DRAW'G No. / 部品番号 PARTS No. SY-0301- <input type="text" value=""/>	